



Schuifafsluiter, draad BSP (RVS)
Gate valve, BSP threads (S.S.)



Maat	A	H	L	W	Artikelnr.
1/2"	15	92	55	70	GAVLV6021G
3/4"	20	97	60	70	GAVLV6026G
1"	25	108.5	65	80	GAVLV6033G
1.1/4"	32	123.5	76.5	80	GAVLV6042G
1.1/2"	40	146	85	90	GAVLV6048G
2"	50	162	95	100	GAVLV6060G
2.1/2"	65	260	116	100	GAVLV6073G
3"	80	295	131	120	GAVLV6088G

Nr.	Parts	Material
1	Body	ASTM-A351-CF8M (316L)
2	Disc	ASTM-A351-CF8M
3	Stem	SS316
4	Joint gasket	PTFE
5	Snapwasher	ASTM-A351-CF8M
6	Stem packing	PTFE
7	High washer	SS304
8	Packing nut	ASTM-A351-CF8M
9	Hand weel	CAST ALUMINIUM
10	Plate	ALUMINIUM
11	Wheel nut	SS304

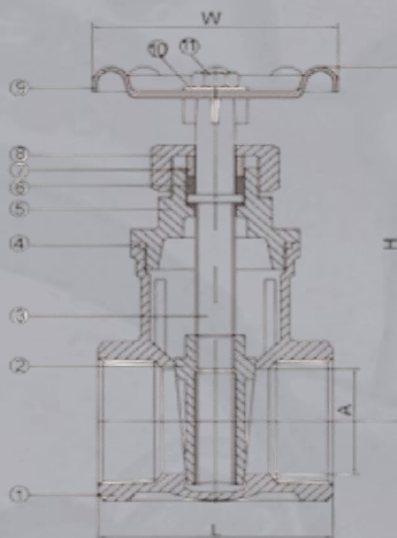

Schuifafsluiter, geflensd, ANSI 150 A105/N
Gate valve, flanged ends, ANSI 150 A105/N



Maat	d	L	H	D0	D	Artikelnr.
1/2"	10.5	108	157	80	90	GAVLV150B21021
3/4"	13	117	163	80	100	GAVLV150B21026
1"	17	127	194	105	110	GAVLV150B21033
1.1/4"	22	140	196	140	115	GAVLV150B21042
1.1/2"	29	165	217	140	125	GAVLV150B21048
2"	36	178	251	160	150	GAVLV150B21060

Nr.	Parts	Material
1	Body	ASTM A105/N
2	Seat	ASTM A276 - 410 + STL
3	Wedge	ASTM A182 F6a
4	Stem	ASTM A276 - 410
5	Body gasket	AISI 304 + graphite
6	Bolt	ASTM A193 Gr. B7
7	Nut	ASTM A194 Gr. 2H
8	Bonnet	ASTM A105/N
9	Stem packing	Graphite
10	Stem nut	ASTM A276 - 410
11	Hand wheel	Cast Iron

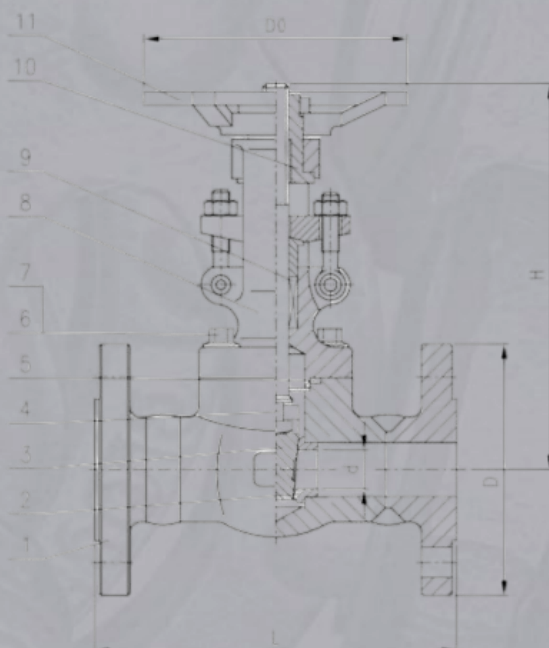

- ◆ Flanged ends according to ANSI B 16.5
- ◆ Max. working pressure 19 Bar.
- ◆ Working temperature -29°C / 420°C



Schuifafsluiter staal, 800 pondsklasse, socket weld einden
 Gate valve C.S., class 800, SW ends



Maat	d	S.W	L	H	D0	Artikel nr.
1/2"	10	21.8	79	161	100	GAVLV800SW21021
3/4"	13.5	27.1	92	163	100	GAVLV800SW21026
1"	18	33.8	111	196	125	GAVLV800SW21033
1.1/4"	24	42.6	120	223	160	GAVLV800SW21042
1.1/2"	30	48.7	120	251	160	GAVLV800SW21048
2"	36.5	61.1	140	290	180	GAVLV800SW21060

Nr.	Parts	Material
1	Body	ASTM-A105/N
2	Seat	ASTM-A276-410 + STL.
3	Wedge	ASTM-A182 F6a
4	Stem	ASTM-A276-410
5	Body Gasket	304L + graphite
6	Bonnet bolt	ASTM-A193 Gr. B7
7	Bonnet nut	ASTM-A194 Gr. 2H
7	Bonnet	ASTM-A105/N
8	Stem packing	Graphite
9	Stem nut	ASTM-A276-410
10	Handweel	Cast Iron

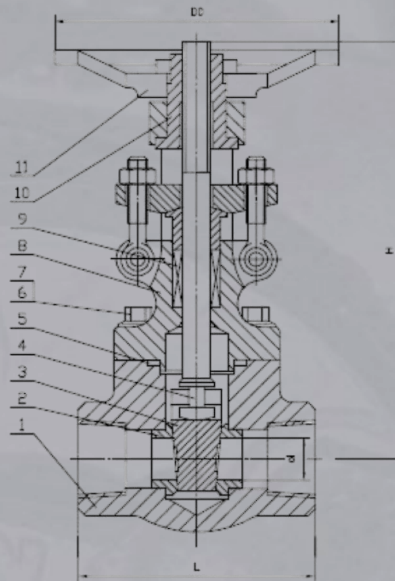

- ◆ Socket welds according to ANSI B 16.11
- ◆ Max. working pressure 140 Bar.
- ◆ Working temperature $-29^{\circ}\text{C} / 420^{\circ}\text{C}$

** Let op, ook te bestellen met NPT binnendraad. Artikel = GAVLV800NPT21, gevolgd door maatvoering